



S 4 0 8 8 E (S M 4 6 8 8 E)

Platform

Working Height	14.02 m	(46 ft)
Platform Height	12.19 m	(40 ft)
Capacity	680 kg	(1500 lbs)

Dimensions

Platform Size	2.23x3.56 m	(88x140 in)
Overall Height	2.85 m	(112 in)
Overall Length	3.91 m	(154 in)
Overall Width	2.24 m	(88 in)
Wheelbase	2.34 m	(92 in)
Inside Turning Radius	4.39 m	(173 in)
Outside Turning Radius	7.06 m	(278 in)
Ground Clearance	0.34 m	(13 in)

Performance

Maximum Drive Speed	4 km/h	(2.5 mph)
Gradeability	18%	
Lift Speed	63 secs	
Lower Speed	62 secs	
Weight	6078 kg	(13400 lbs)

Power Source

Electric

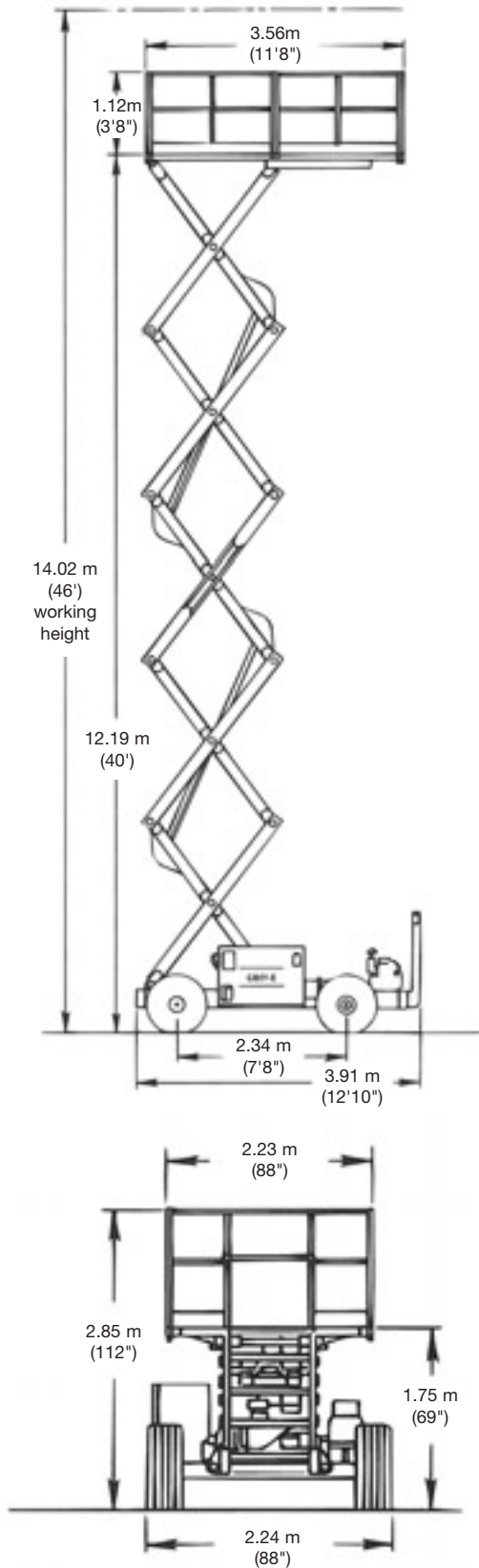
**FEATURES**

Deck extension 1.22m (48 in) roll out

Eight 6 volt 350 amp-hr. batteries

One 110/220 volt, 50/60 HZ 25 amp automatic battery charger

12 x 16.5 foam filled tyres

Motion Alarm

Tilt alarm with function cut out

Right hand side cover (covers electric motors)

220V AC Wiring to platform and chassis

Metal scissor guards

Two wheel drive/two wheel steer

Hourmeter

Low voltage cut out

Battery level indicator

Manually operated emergency lowering

OPTIONS

- 4 wheel steer

- 110V AC connections to platform